

# Compressed Air Cooling Air ACOC/ACOCH Series

## BRAZED ALUMINUM CONSTRUCTION

### Features

- **Combination Welded Cores – Air & Oil Core**
- **Brazed Aluminum Core/Bar and Plate**
- **Excellent for Field Conversions**
- **Vertical Air Flow**
- **Compact Design**
- **Light Weight**
- Compact, high performance all aluminum core assembly
- Designed specifically for rotary screw compressors
- Ideal for converting water cooled units to air cooled
- Eliminates high water and sewer costs
- Eliminates corrosion problems associated with water cooled units
- Vertical air flow works well for heat recovery
- State-of-the-art heat transfer technology
- Detachable Legs on ACOC (shipped unattached)  
Fixed Mounting Feet on ACOCH
- CRN Available



AIR COOLED ACOC(H)

### Ratings

**Maximum Operating Pressure** 250 psi  
**Maximum Operating Temperature** 350°F

### Materials

**Legs** Steel with Baked Enamel Finish  
**Shroud** Steel  
**Core** Brazed Aluminum Bar and Plate  
**Fan** Aluminum Hub, Plastic Blades  
**Motor** TEFC

### How to Order

|                             |   |   |   |   |
|-----------------------------|---|---|---|---|
| <b>ACOC</b>                 | - |   | - |   |
| Model Series<br><b>ACOC</b> |   | Model Size Selected<br><b>400</b><br><b>725</b><br><b>950</b><br><b>1200</b><br><b>1600</b><br><b>2000</b><br><b>2500</b><br><b>3000</b><br><b>3500</b> |   | Specify Motor Required<br><b>0</b> - No Motor<br>(includes Fan Blade & Fan Guard)<br><b>2</b> - Single Phase<br><b>3</b> - Three Phase<br><b>6</b> - 575 Volt |

|                              |   |  |   |   |
|------------------------------|---|--|---|---|
| <b>ACOCH</b>                 | - |  | - |   |
| Model Series<br><b>ACOCH</b> |   | Model Size Selected<br><b>400</b><br><b>725</b><br><b>950</b><br><b>1200</b><br><b>1600</b><br><b>2000</b> |   | Specify Motor Required<br><b>0</b> - No Motor<br>(includes Fan Blade & Fan Guard)<br><b>2</b> - Single Phase<br><b>3</b> - Three Phase<br><b>6</b> - 575 Volt |

# Dimensions

## ACOC – Vertical Air Flow

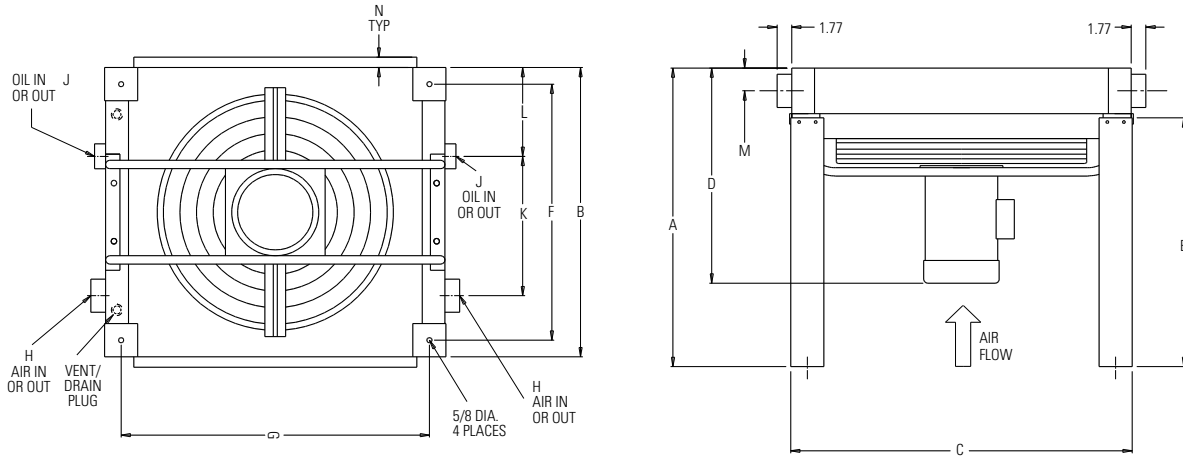

| Model     | A     | B     | C     | D Approx | E     | F     | G     | H NPT | J NPT | K     | L     | M    | N    |
|-----------|-------|-------|-------|----------|-------|-------|-------|-------|-------|-------|-------|------|------|
| ACOC-400  | 34.20 | 17.96 | 22.68 | 20.86    | 30.00 | 13.96 | 18.68 | 1.50  | 1.00  | 8.35  | 5.08  | 1.85 | 1.25 |
| ACOC-725  | 34.20 | 22.37 | 30.56 | 20.86    | 30.00 | 18.37 | 26.56 | 1.50  | 1.00  | 10.55 | 6.34  | 1.85 | 1.25 |
| ACOC-950  | 36.01 | 26.78 | 37.24 | 23.62    | 30.00 | 22.78 | 33.24 | 2.00  | 1.25  | 12.67 | 7.64  | 2.76 | 1.25 |
| ACOC-1200 | 36.01 | 26.78 | 41.19 | 25.51    | 30.00 | 22.78 | 37.19 | 2.00  | 1.25  | 12.83 | 7.64  | 2.76 | 1.25 |
| ACOC-1600 | 36.01 | 34.89 | 41.19 | 27.51    | 30.00 | 30.89 | 37.19 | 2.50  | 1.50  | 16.81 | 10.08 | 2.76 | 1.25 |
| ACOC-2000 | 36.01 | 37.88 | 51.04 | 28.51    | 30.00 | 33.88 | 47.04 | 2.50  | 1.50  | 18.47 | 10.98 | 2.76 | 1.25 |
| ACOC-2500 | 36.01 | 43.70 | 49.07 | 28.51    | 30.00 | 39.70 | 45.07 | 3.00  | 2.00  | 21.11 | 12.83 | 2.76 | 1.25 |
| ACOC-3000 | 36.01 | 52.52 | 51.04 | 30.51    | 30.00 | 48.52 | 47.04 | 3.00  | 2.00  | 33.30 | 8.00  | 2.76 | 1.25 |
| ACOC-3500 | 36.01 | 56.30 | 51.04 | 30.51    | 30.00 | 52.30 | 47.04 | 4.00  | 2.50  | 27.40 | 18.43 | 2.76 | 1.25 |

Note: We reserve the right to make reasonable design changes without notice. All Dimensions are in inches.

## ACOCH – Horizontal Air Flow

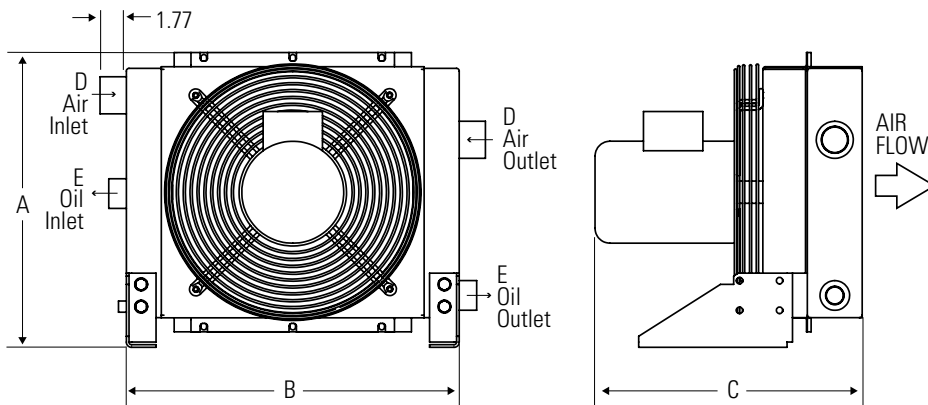

| Model      | A     | B     | C Approx. | D NPT | E NPT |
|------------|-------|-------|-----------|-------|-------|
| ACOCH-400  | 19.88 | 22.45 | 20.86     | 1.50  | 1.00  |
| ACOCH-725  | 24.37 | 30.56 | 20.86     | 1.50  | 1.00  |
| ACOCH-950  | 28.82 | 37.24 | 23.62     | 2.00  | 1.25  |
| ACOCH-1200 | 28.82 | 41.19 | 25.51     | 2.00  | 1.25  |
| ACOCH-1600 | 36.89 | 41.19 | 27.51     | 2.50  | 1.50  |
| ACOCH-2000 | 39.53 | 50.79 | 28.51     | 2.50  | 1.50  |

Note: We reserve the right to make reasonable design changes without notice. All Dimensions are in inches.

# Selection Procedure

**Step 1 Determine the Air Compressor's motor horsepower.**

**Step 2 Enter the chart** at the motor horsepower to select the correct model.

**Step 3 Check the aftercooler SCFM.** The SCFM of air discharged from the air compressor must be equal to or less than the value in the chart for the model selected. If it is not, choose a larger model. If the SCFM is unknown, multiply the air compressor's motor horsepower by 4.5 to determine the SCFM capacity required.

## Sizing

1. Oil flow is .45 GPM/HP.
2. Oil pressure drop - 15 psi or less
3. Oil heat transfer based on 100°F E.T.D.  
(E.T.D. = Entering Temperature Difference)  
(E.T.D. = Oil in Temperature - Ambient Air Temperature)
4. Air aftercooler pressure drop - 3 psi or less.
5. E.T.D. Temperature Correction Factor:

$$HP_{\text{chart}} = HP_{\text{compressor}} \times \frac{100}{\text{Desired E.T.D.}}$$

## Recommended Typical Installation

1. Support piping as needed. Flexible connectors must be properly installed to validate warranty.
2. Coolers should not operate in ambient temperatures below 35°F (1°C). Consult factory for recommendations.
3. The fan cannot be cycled.
4. AHP coolers operated outdoors must be protected from weather. Consult factory for recommendations.
5. If ductwork or additional static resistance is added to the cooler airstream, an auxiliary air mover may be required.

| Model         | Compressor H.P. | Aftercooler Maximum SCFM with 100 PSI Air & A 15°F Approach Temperature |
|---------------|-----------------|---|
| ACOC(H)-400   | 15-35           | 175   |
| ACOC (H)-725  | 40-55           | 275   |
| ACOC (H)-950  | 60-85           | 425   |
| ACOC (H)-1200 | 90-120          | 600   |
| ACOC (H)-1600 | 125-155         | 775   |
| ACOC (H)-2000 | 160-225         | 1125  |
| ACOC-2500     | 230-275         | 1375  |
| ACOC-3000     | 280-325         | 1625  |
| ACOC-3500     | 330-360         | 1800  |

## Maintenance

Periodic cleaning of the fins with compressed air is needed to remove the accumulation of dirt and dust. Check the automatic drain on the separator (not included) periodically.

If the inside of the tubes need to be cleaned of oil and carbon, use a chlorinated solvent. Do not use strong solvents. Do not use acids or caustic cleaners.

## Electric Motor and Fan Data

| Model        | Fan CFM           | Motor H.P. | Voltage                                   | Phase  | Full Load Amps 230V | Hz                         | RPM               | Nema Frame | Thermal Over-load | Net Weight Lbs. | Approx. Shipping Wt. (Lbs.) |
|--------------|-------------------|------------|---|--------|---------------------|----------------------------|-------------------|------------|-------------------|-----------------|-----------------------------|
| ACOC(H)-400  | 2200<br>1825/2200 | 1.0        | 115/208-230<br>208-230/460 <sup>(2)</sup> | 1<br>3 | 6.0<br>3.6/3.2      | 60 <sup>(1)</sup><br>50/60 | 3450<br>2850/3450 | 56C        | No                | 105             | 136                         |
| ACOC(H)-725  | 3600<br>3025/3600 | 1.5        | 115/208-230<br>208-230/460 <sup>(3)</sup> | 1<br>3 | 8.5<br>4.8/4.2      | 60 <sup>(1)</sup><br>50/60 | 3450<br>2850/3450 |            |                   | 149             | 155                         |
| ACOC(H)-950  | 4700              | 1.5        | 115/208-230<br>208-230/460                | 1<br>3 | 8.6<br>4.6          | 60                         | 1740              | 145TC      |                   | 223             | 280                         |
| ACOC(H)-1200 | 7000              | 5.0        | 230                                       | 1      | 23.0                |                            |                   | 184TC      |                   | 297             | 410                         |
|              |                   | 3.0        | 208-230/460                               | 3      | 8.8                 |                            |                   | 182TC      |                   |                 |                             |
| ACOC(H)-1600 | 9700              | 5.0        | 208-230/460                               | 3      | 13.4                |                            |                   | 184TC      |                   | 345             | 495                         |
| ACOC(H)-2000 | 11000             | 7.5        | 230/460                                   |        | 19.6                |                            |                   | 213TC      |                   | 495             | 530                         |
| ACOC-2500    | 14000             |            |   |        | 24.8                |                            |                   | 215TC      |                   | 522             | 540                         |
| ACOC-3000    | 17500             | 10.0       | 230/460                                   | 3      | 24.8                |                            |                   | 215TC      |                   | 655             | 780                         |
| ACOC-3500    | 17500             |            |   |        |                     |                            |                   |            |                   | 690             | 820                         |

**All motors shown are TEFC—Other motor options available upon request.**

Published electrical ratings are approximate and may vary because of motor brand. Actual ratings are on motor nameplate.

<sup>(1)</sup> May also be operated at 50 Hz. Consult factory for details.

<sup>(2)</sup> 50 Hz voltage: 190 - 200 - 208 - 220/380 - 400 - 415 - 440

<sup>(3)</sup> 50 Hz voltage: 190 - 208/380 - 415

## Bottom view of cooler to illustrate piping

