

Fluid Cooling P-Bar Series Mobile MA

BRAZED ALUMINUM CONSTRUCTION

Features

- Now available with fully reversible Brushless DC Fan Motors
- Bar and Plate Brazed Aluminum Core
- Rugged, lightweight, and compact
- Provides the best heat transfer per given envelope size while minimizing pressure drop
- Air-side fin design minimizes fouling and static pressure ensuring long-term, reliable performance
- Fans compliant with IP 68 (Brushed) and IP6K9K (Brushless) with fully sealed motors
- Welded aluminum fittings/ports and manifolds ensure structural integrity
- Standard SAE ports – NPT and BSPP ports available
- Customized units are available to meet your specific performance requirements
- Optional temperature sensors (see pg. 191)



Now offering axial fans equipped with brushless DC electric motors on standard MA Series!



Brushless DC Option:
Longer life, water proof & sealed to IP68, spark free, quieter and small in size.

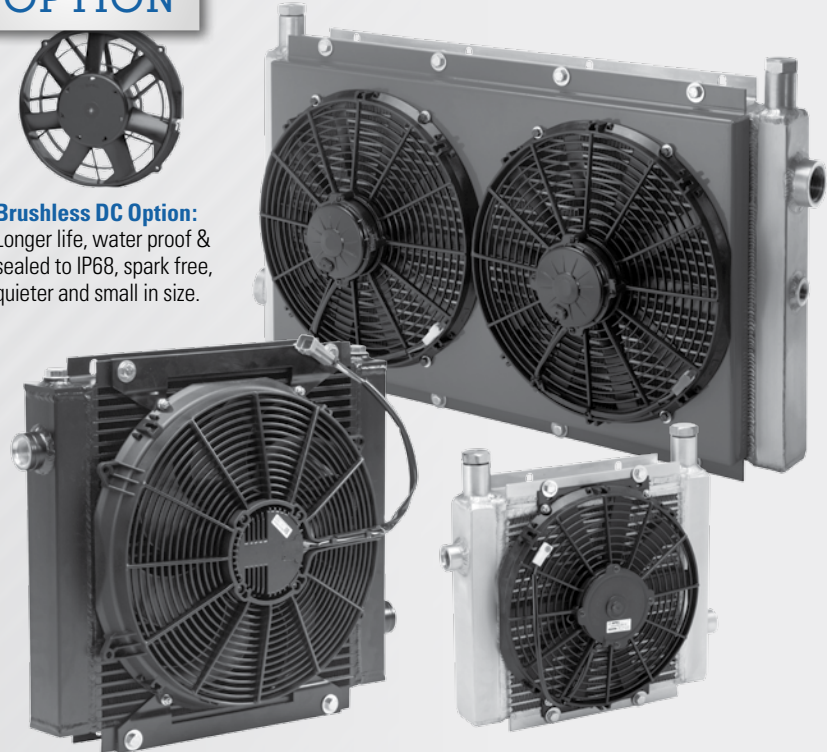

AIR COOLED MA

Ratings

Maximum Operating Pressure

250 psi (17 BAR)

Maximum Operating Temperature

300° F (150° C)

Fluid Compatibility

Petroleum/mineral oils

Oil/water emulsion

Water/ethylene glycol

Materials

Core Brazed Aluminum Bar and Plate

- Tanks – 5052 Aluminum
- Nose Bar & Little Bar – 3003-H Aluminum
- Air Fin, Plate, Turbulator & End Plate – 3003-O Aluminum

Connections Aluminum

Core Mounting Brackets Brazed Aluminum

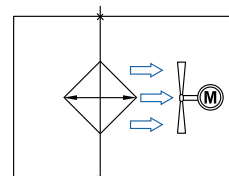

Without Bypass

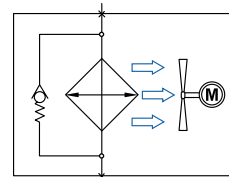

With Bypass



30/60 psi
Bypass
available

How to Order

Model Series	Model Size Selected*	Connection Type	Bypass (MAR)**	Specify Motor Required
MA	3 • 3.5 • 4 • 12 • 18	1 - NPT	Blank - No Bypass (MA)	Blank - No Fan (Core Only)
(MAR)	32 • 48 • 232 • 248	2 - SAE	30 - 30 PSI	4A - 12 VDC
	8 • 14 • 20 • 66 • 82 • 120	3 - BSPP	60 - 60 PSI	4B - 24 VDC
				4ABL - 12 VDC Brushless Fan***

*MA-8, MA-14, MA-20, MA-66, MA-82, MA-120 are not available with a DC fan.

**Bypass available on MA-12, MA-18, MA-32, MA-48, MA-66, MA-82, MA-120, MA-232, MA-248 only. (MAR)

***Brushless DC fan is currently available in 12V DC only.

Dimensions - Fan/Core

MA-3

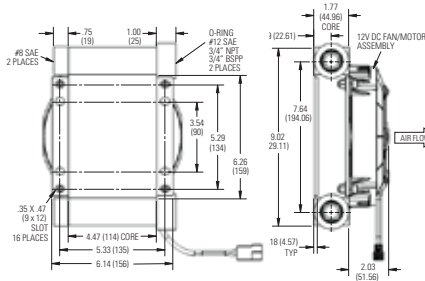

MA-3.5

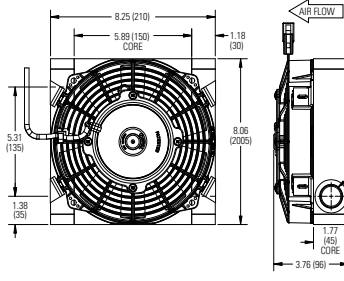

MA-4

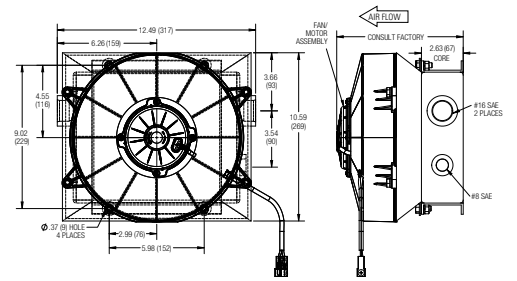

MA-12, MA-18, MA-32

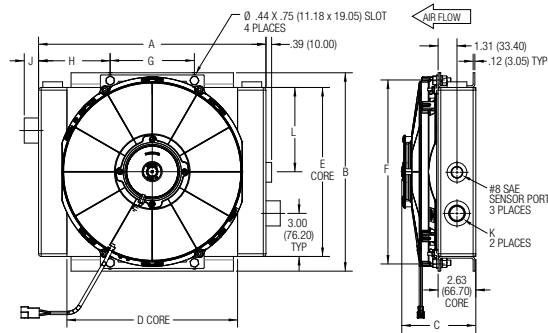

MA-232

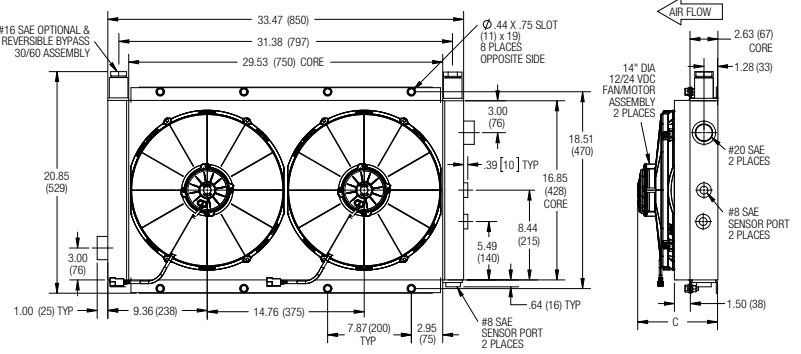

MA-48

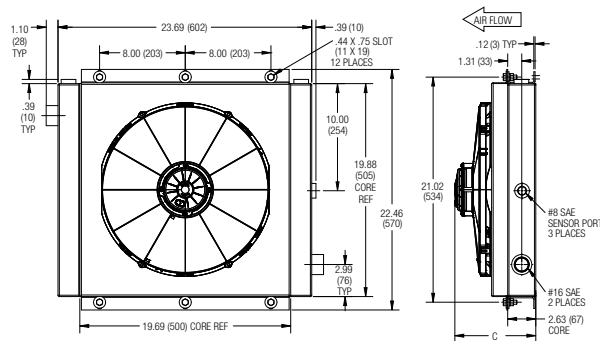

MA-248

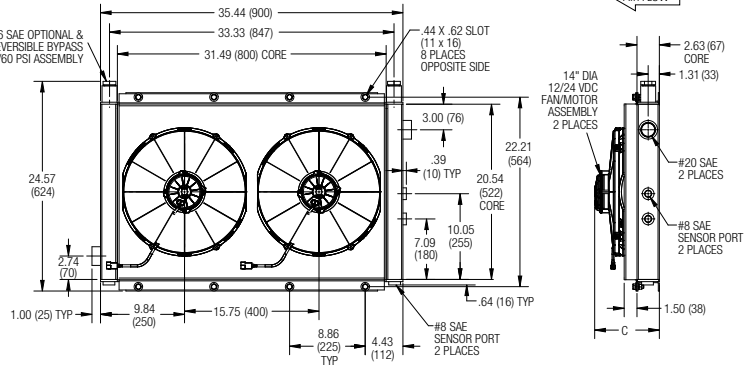

Model	A	B	C	D	E	F	G	H	J	K		DC Amp Draw		CFM (CMM)	Approx. Ship Wt lbs (kg)
										SAE	NPT & BSPP	12V	24V		
MA-3	See diagram above									5.7	3.6	300 (8.50)	6 (2.72)		
MA-3.5	See diagram above									12.5	6.3	370 (10.48)	9 (4.08)		
MA-4	See diagram above									12.5	6.3	363 (10.28)	16 (7.26)		
MA-12	13.82 (351)	11.97 (304)	Consult factory for dimension	9.88 (251)	9.85 (250)	10.98 (279)	5.71 (145)	4.06 (103)	1.00 (25)	#12 SAE	3/4"	5.00 (127)	6.3	521 (14.75)	19 (8.62)
MA-18	15.84 (204)	13.82 (351)		11.89 (302)	12.01 (305)	12.82 (326)	5.87 (149)	4.99 (127)	1.00 (25)	#12 SAE	3/4"	5.91 (150)	10.6	783 (22.17)	23 (10.43)
MA-32	19.69 (500)	18.46 (469)		15.75 (400)	16.34 (415)	17.32 (440)	12.00 (305)	3.84 (98)	1.10 (28)	#16 SAE	1"	8.07 (205)	22.2	1368 (38.74)	28 (12.70)
MA-48	See diagram above									22.2	11.1	1637 (46.40)	45 (20.40)		
MA-232	See diagram above									19.3*	9.7*	2234 (63.26)	65 (29.48)		
MA-248	See diagram above									19.3*	9.7*	2904 (82.24)	90 (40.80)		

Note: We reserve the right to make reasonable design changes without notice. All dimensions are in inches (millimeters) unless noted otherwise.
*AMP draw listed as per FAN.

Dimensions - Core Only

MA-3

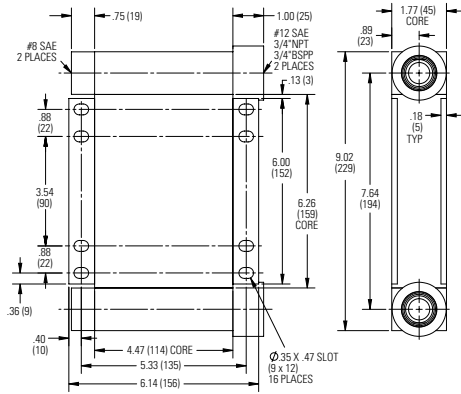

MA-4

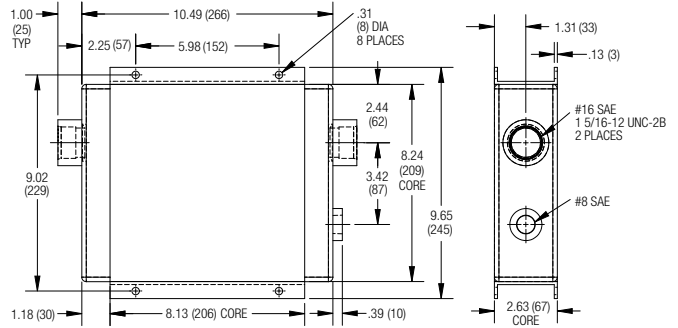

MA-8, MA-14, MA-20

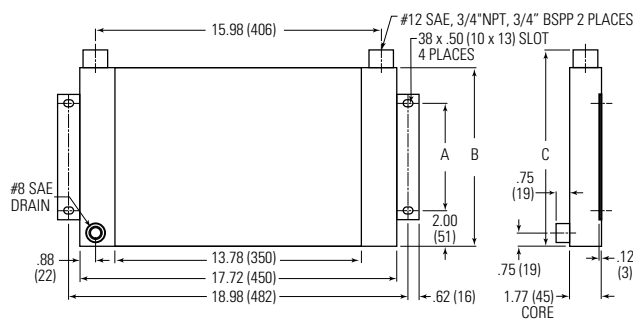

MA-12 thru MA-120

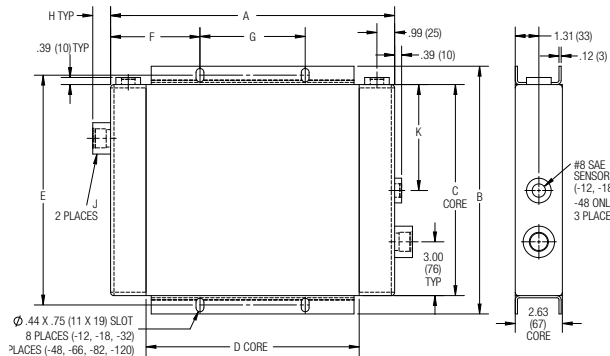

MA-232

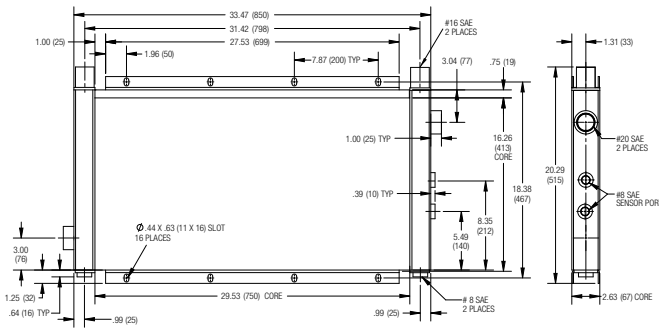

MA-248

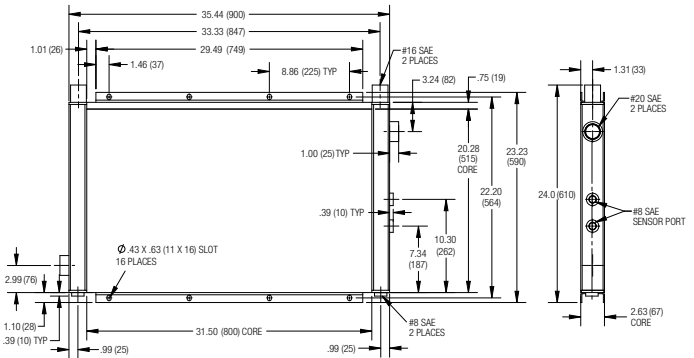

Model	A	B	C	D	E	F	G	H	J			Approx. Ship Wt. lbs (kg)
									SAE	NPT & BSPP	K	
MA-3	See diagram above										4 (1.81)	
MA-4	See diagram above										7 (3.18)	
MA-8	3.00 (76)	5.67 (144)	6.65 (169)									10 (4.54)
MA-12	13.82 (351)	11.97 (304)	9.85 (250)	9.88 (251)	10.98 (279)	4.06 (103)	5.71 (145)	1.00 (25)	#12	3/4"	5.00 (127)	15 (6.8)
MA-14	6.00 (152)	10.00 (254)	10.98 (279)									14 (6.35)
MA-18	15.84 (402)	13.82 (351)	12.01 (305)	11.89 (302)	12.82 (326)	4.99 (127)	5.87 (149)	1.00 (25)	#12	3/4"	5.91 (150)	18 (8.16)
MA-20	10.00 (254)	14.33 (364)	15.31 (389)									18 (8.16)
MA-32	19.69 (500)	18.46 (469)	16.34 (415)	15.75 (400)	17.32 (440)	3.84 (98)	12.00 (305)	1.00 (25)	#16	1"	8.07 (205)	28 (12.7)
MA-48	23.69 (602)	22.09 (561)	20.12 (511)	19.76 (502)	21.02 (534)	3.85 (98)	8.00 (203)	1.00 (25)	#16	1"	10.00 (254)	41 (18.60)
MA-66	27.56 (700)	25.83 (656)	23.39 (594)	23.62 (600)	24.72 (628)	3.78 (96)	10.00 (254)	1.58 (40)	#20	1 1/4"		50 (22.68)
MA-82	31.46 (799)	27.68 (703)	25.55 (649)	27.52 (699)	26.57 (675)	5.73 (146)	10.00 (254)	2.00 (51)	#24	1 1/2"		65 (29.48)
MA-120	31.46 (799)	39.6 (1006)	37.44 (951)	27.52 (699)	38.38 (975)	5.73 (146)	10.00 (254)	2.00 (51)	#24	1 1/2"		88 (39.92)
MA-232	See diagram above										55 (24.95)	
MA-248	See diagram above										80 (36.29)	

Note: We reserve the right to make reasonable design changes without notice. All dimensions are in inches (millimeters) unless noted otherwise.

Performance Curves

MA Models with DC Fan Assemblies

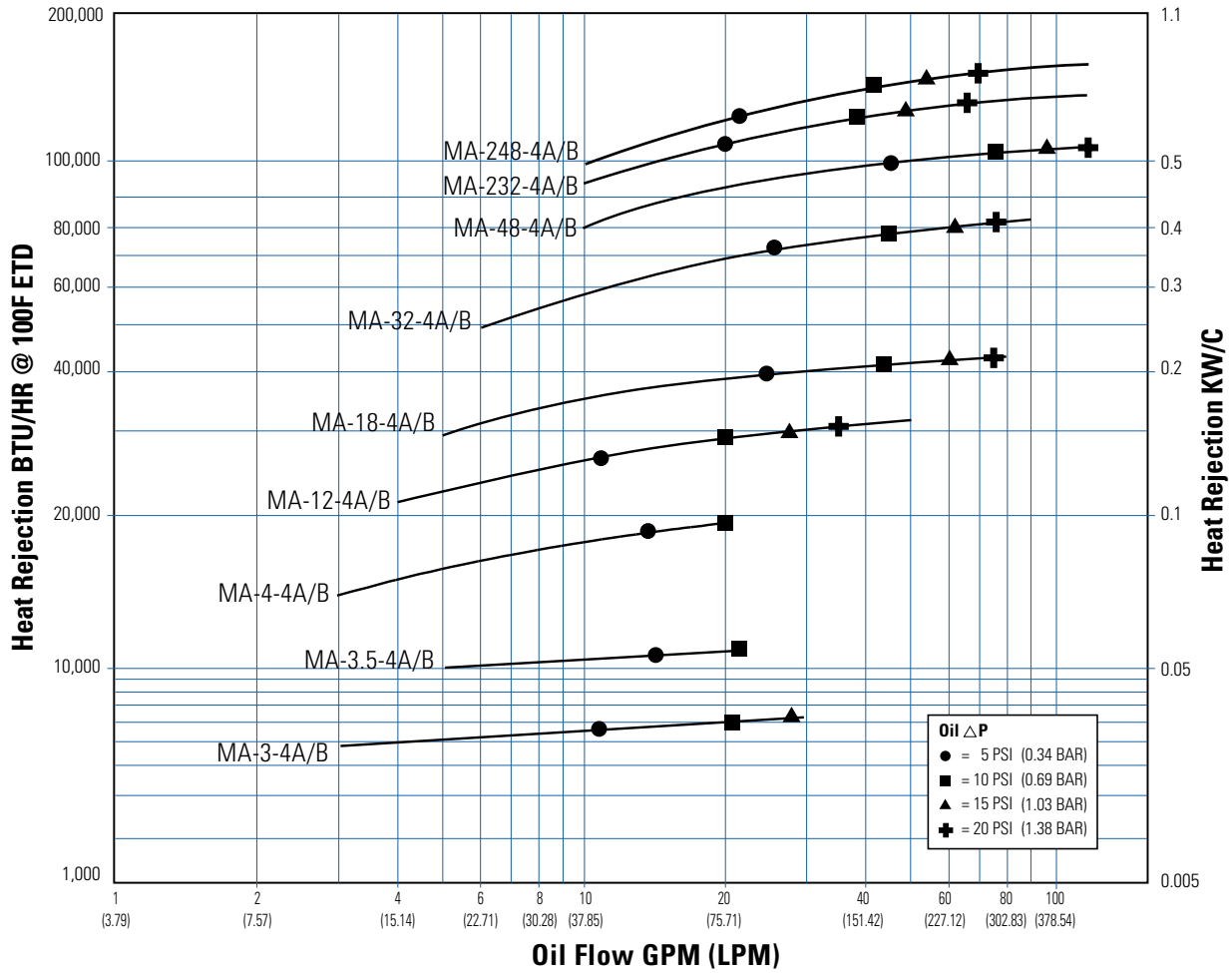

Variable speed Brushless DC fans are more efficient than the standard DC fans.
As a result, the same thermal performance can be achieved at lower speed/sound level.

Performance Curves

MA Models (No Fan, Core Only)

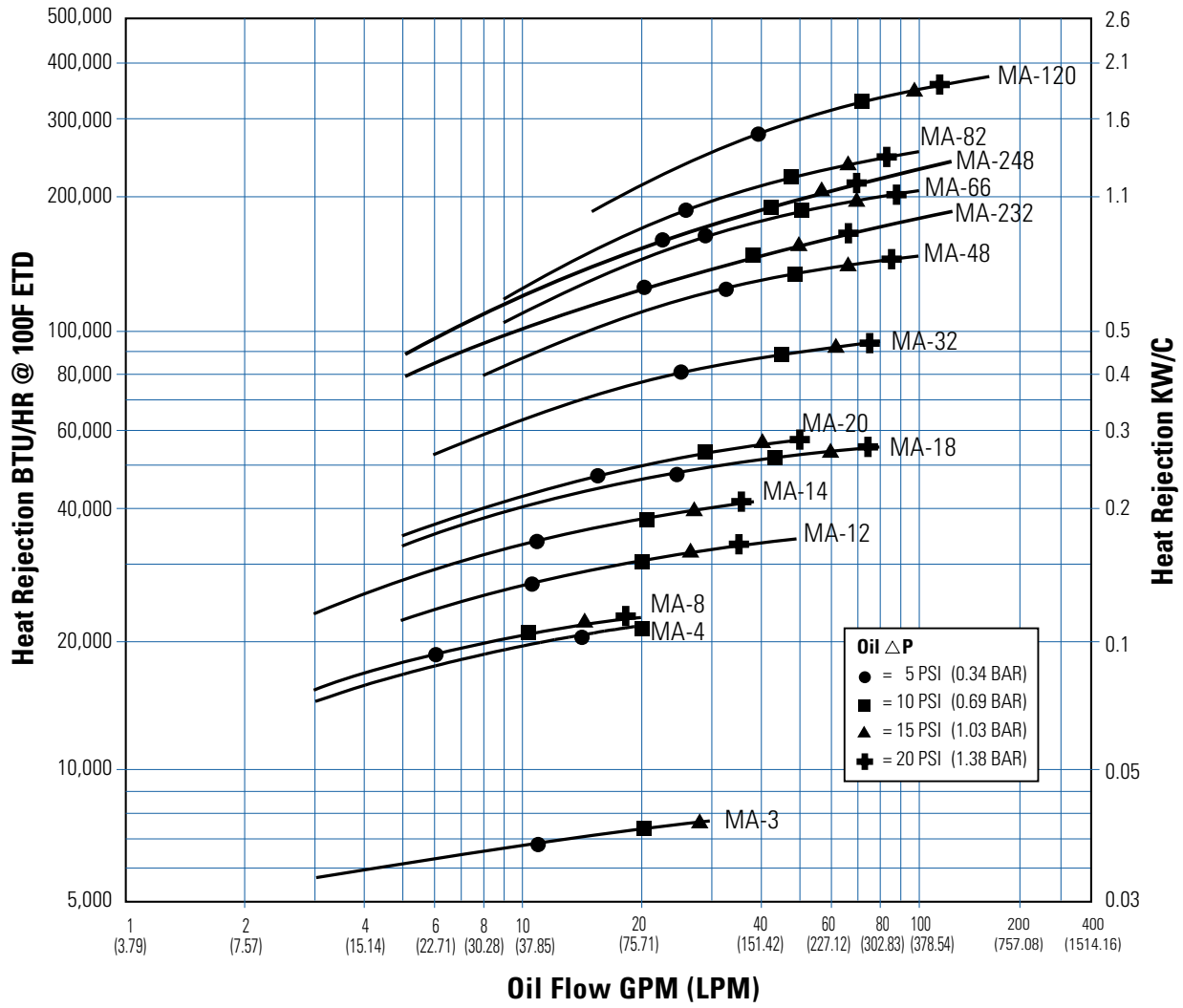

AIR COOLED MA

Selection Procedure

Step 1 Determine Heat Load. Typical Rule of Thumb, - size cooler for 1/3 of the input horsepower. Heat load may be expressed as either Horsepower or BTU/HR or KW/°C.

$$HP = BTU/HR \div 2545$$

$$BTU/HR = HP \times 2545$$

$$BTU/HR = \frac{KW}{^{\circ}C} \times 1895 \times E.T.D.(^{\circ}F)$$

Step 2 Determine Entering Temperature Difference. (Actual E.T.D.) (E.T.D.= Entering oil temperature – Entering Ambient air temperature) The entering oil temperature is generally the maximum desired system oil temperature.

Entering air temperature is the highest Ambient Air temperature the application will see, plus – add any pre-heating of the air prior to its entering the cooler. Pay special attention if air is drawn from the engine compartment for cooling.

Step 3 Find Air Velocity Correction Factor (Skip to Step 4 if using our DC Fan Assembly)

Calculate actual SFPM Air Velocity or SCFM (Standard Cubit Feet per Minute) for selection using the Face Area from the table.

$$SFPM \text{ Air Velocity}^* = \frac{SCFM \text{ Air Flow}}{\text{Square Feet Cooler Face Area}}$$

$$SMPM = \frac{SCMM}{\text{Square Meter Cooler Face Area}}$$

(SCFM Air Flow= SFPM Air Velocity x Square Feet Cooler Face Area)

*If the Air Velocity calculated is different than the value in Step 4, then recheck Corrected oil Pressure drop.

Step 4 Determine the Corrected Heat Dissipation to use the Curves
ENGLISH Version

$$\text{Corrected Heat Rejection} = \frac{BTU/HR}{\text{Heat Load}} \times \left[\frac{100^{\circ}F}{\text{Desired E.T.D}} \times \frac{\text{Air Velocity}}{\text{Correction Factor}} \right]$$

(BTU/HR) to use with selection chart

(Air Factor value not needed if using provided DC Fan assembly; Omit in formula)

METRIC Version

$$\text{Corrected Heat Rejection} \left[\frac{KW}{^{\circ}C} \right] = \frac{\text{Heatload (kw)}}{\text{Desired E.T.D } (^{\circ}C) \times \text{Correction Factor}} \times \text{Air Velocity}$$

Step 5 Select Model From Curves Enter the Performance Curves at the bottom with the GPM oil flow and proceed upward to the adjusted Heat Rejection from Step 4. Any Model or Curve on or above this point will meet these conditions.

Step 6 Calculate Oil Pressure Drop Find the oil pressure drop correction factor and multiply it by the Oil Pressure Drop found on performance curve.

Listed Performance Curves are based on:

- 50 SSU (11 cSt) oil
- 1000 Standard Feet per Minute (SFPM) (304.8 MPM) Air Velocity
- 100° F (55.56° C) Entering Temperature Difference (E.T.D.)

If your application conditions are different, then continue with the selection procedure.

