

Compressed Air Cooling Air UPA Series

COPPER TUBE CONSTRUCTION

Features

- Full Line of Sizes and Features
- Energy Efficient
- High Performance
- Low flows to 100 CFM
- Floor or Suspended Mounting
- Lightweight, may be Shipped UPS
- Ratings Based on Comprehensive Testing
- Attractive, Durable Baked Enamel Finish
- Floor or Suspended Mounting
- Detachable Legs (shipped unattached)



Ratings

Maximum Operating Pressure 250 PSIG
Maximum Operating Temperature 350° F

Materials

Cabinet Steel with Baked Enamel Finish
Core Aluminum Fins on Copper Tubes
Fan Heavy Gauge Aluminum with Steel Hub
Motor Open Vented
Fan Guard Zinc Chromate Plated Steel

AIR COOLED UPA

How to Order

UPA	-	<input type="text"/>	-	<input type="text"/>
Model Series UPA		Model Size Selected		Specify Motor Required 0 - No Motor 1 - Single Phase 60 Hz ODP 115 Volt

Dimensions

Models UPA-20 & UPA-35

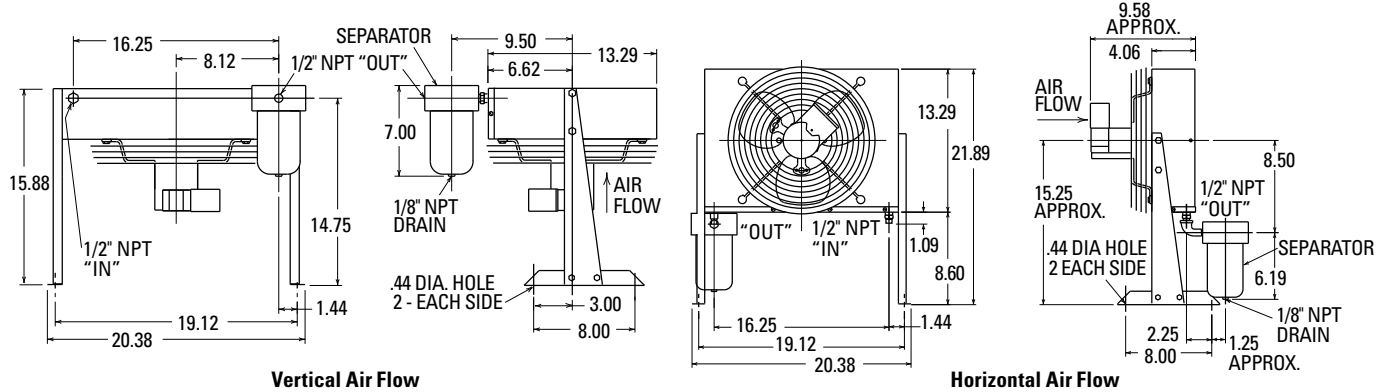

Models UPA-50 & UPA-100

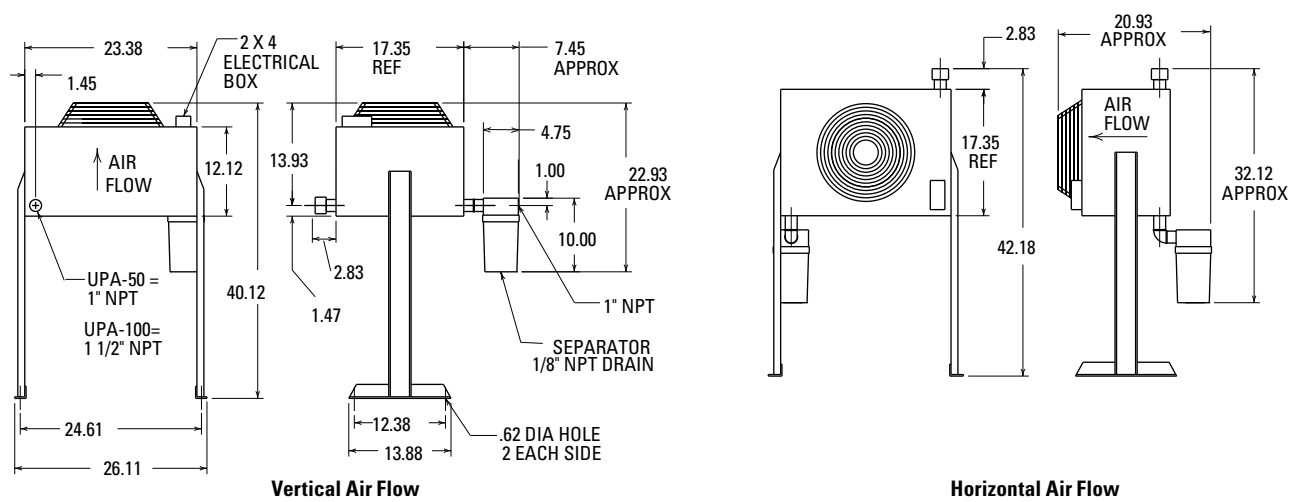

Note: We reserve the right to make reasonable design changes without notice. All dimensions are in inches.

Capacity Selection Chart Max. SCFM @ 5, 10, 15 and 20°F Approach

Inlet Temp. °F	150				200				250				300				350				Recommended Optional Separator Model Number	
	Approach Temp. °F	5	10	15	20	5	10	15	20	5	10	15	20	5	10	15	20	5	10	15		20
Model Number	UPA-20	17	35*	35*	35*	11	22	35	35*	8	16	20	35	6	12	19	26	5	10	15	21	S-50M or AD
	UPA-35	29	43*	43*	43*	17	36	43*	43*	12	27	35	42*	10	20	31	42*	8	16	26	35	
	UPA-50	43	72	72*	72*	28	50	70	72*	22	35	50	70	18	32	45	57	15	28	39	50	S-100M or AD
	UPA-100	95	125*	125*	125*	66	111	125*	125*	52	88	100	125*	44	74	100	125	38	64	86	108	

Above specifications are based on 80 to 125 PSIG operating pressures. Maximum pressure drop, less than 3 psi.
 A flexible metal hose must be properly installed between the compressor and aftercooler to validate warranty.
 *Maximum ratings restricted by pressure drop, actual thermal capacities are higher.

Electric Motor & Fan Data

Model	Fan CFM	Motor H.P.	Voltage	Phase	Full Load Amps	Hz	RPM	Nema Frame	Thermal Overload	Approx. Shipping Weight (Lbs.)
UPA-20	615	1/12	115/230	1	2.4/1.2	60	1550	Custom	Yes	25
UPA-35										27
UPA-50	945				61					
UPA-100					67					

Published electrical ratings are approximate, and may vary because of motor brand. Actual ratings are on motor nameplate.